

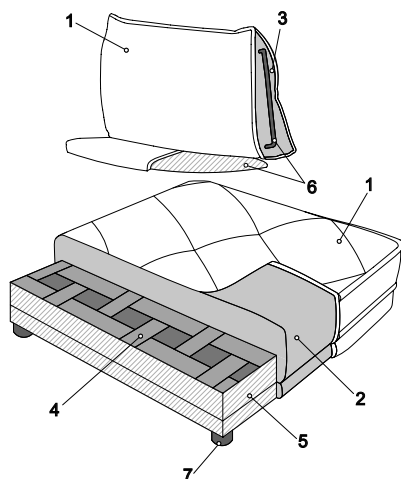

CARATTERISTICHE - FEATURES



1. Rivestimento
Sofa covering
2. Imbottitura seduta: poliuretano espanso HT 35 kg/m³ ricoperto con resinato accoppiato
Seat padding: expanded polyurethane HT 35kg/m³ covered with coupled wadding resin
3. Imbottitura schienale: poliuretano espanso a densità differenziata
Backrest padding: expanded polyurethane in variable density
4. Sistema di molleggio: cinghie elastiche incrociate
Springing: suspension with elastic crossing belts
5. Struttura portante: legno massello e multistrato con parti in agglomerato
Structure: solid wood and multilayer frame with parts in plywood and particle board
6. Struttura schienale: base in multistrato e scheletro in metallo
Backrest structure: multilayer base and metal frame
7. Piedi in ABS antiscivolo
Antislip ABS feet

PIEDI - FEET



ABS antiscivolo nero
Black antislip ABS

MODULARITA' - AVAILABLE ELEMENTS

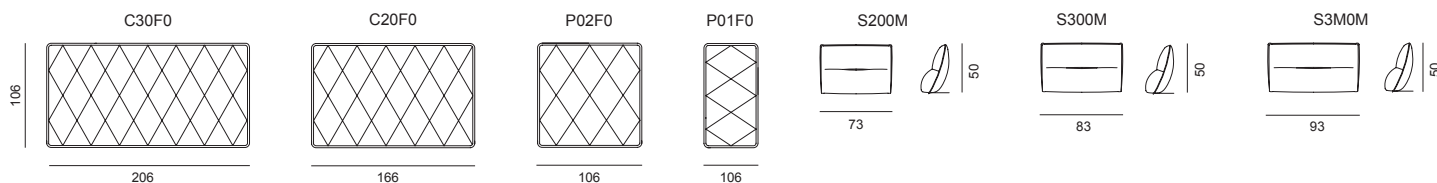

Non sfoderabile - Not removable covers

INFORMAZIONI COMMERCIALI - COMMERCIAL INFORMATION

- Schienale libero posizionabile a piacimento
Removable backrest freely placeable on the sofa

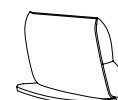

- Ripartizione rivestimento divano STANDARD
STANDARD sofa coating breakdown

● CUS ● STR

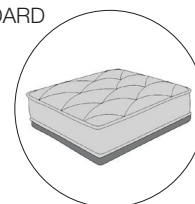

- Ripartizione rivestimento schienale libero STANDARD
STANDARD removable backrest coating breakdown

○ CUS

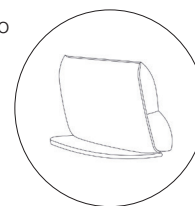

- Le ripartizioni non possono essere modificate
Coating breakdown cannot be changed

- Tutti gli elementi sono rifiniti su tutti i lati
All elements sides are fully upholstered



- Possibilità di realizzare su misura o personalizzazione previa valutazione di fattibilità, secondo preventivo
Possibility of customization, after feasibility assessment, upon quotation